

**FORMULA 16
CATAMARAN
CLASS RULES
2010**



The FORMULA 16 CATAMARAN was designed to a box rule in 2002 by a group of catamaran enthusiasts on 3 continents cooperating via the internet

INDEX

PART I – ADMINISTRATION

Section A – General

A.1	Language	4
A.2	Abbreviations	4
A.3	Authorities.....	4
A.4	Administration of the Class	4
A.5	Class Rules Variations	4
A.6	Class Rules Amendments	5
A.7	Class Rules Interpretation	5
A.8	International Class Fee and ISAF Building Plaque	5
A.9	Record of Measurement Certificates & Numbers	5
A.10	Boat Certification	5
A.11	Initial Boat Certification	5
A.12	Validity of Certificate	6

Section B – Boat Eligibility

B.1	Class Rules and Certification	6
B.2	Flotation Checks	6
B.3	Class Association Markings	6

PART II – REQUIREMENTS AND LIMITATIONS

Section C – Conditions for Racing

C.1	General	7
C.2	Crew	7
C.3	Personal Equipment	7
C.4	Advertising	8
C.5	Portable Equipment	8
C.6	Boat	8
C.7	Hull	9
C.8	Hull Appendages	9
C.9	Rig	10
C.10	Sails	11

Section D– Hull

D.1	Parts	12
D.2	General	12
D.3	Hull Shell	12
D.4	Deck	13
D.5	Beams	13
D.6	Trampoline.....	14
D.7	Assembled Hull	14

Section E – Hull Appendages

E.1	Parts	15
E.2	General	15
E.3	Daggerboard/Centreboard	15
E.4	Rudder Blade, Rudder Stock and Tiller	16

Section F – Rig

F.1	Parts	17
F.2	General	17
F.3	Mast	18
F.4	Boom	19
F.5	Bowsprit	19
F.6	Standing Rigging	19
F.7	Running Rigging	20

Section G – Sails

G.1	Parts	21
G.2	General	21
G.3	Mainsail	21
G.4	Jib	22
G.5	Spinnaker	22

PART III – APPENDICES

H	Class insignia	24
I	Mast Datum.....	25
J	Sail measurement.....	26

INTRODUCTION

This introduction only provides an informal background and the FORMULA 16 CATAMARAN Class Rules proper begin on the next page.

The strict box measurement rule allows manufacturers to develop catamarans that are competitively priced yet allow freedom to builders to develop toward higher levels of performance. Being open to any manufacturer allows many builders and sail makers to compete and so keep costs to a minimum. The Class remains committed to keeping development under control, maintaining a good balance between cost and performance.

F16CA measures or checks hulls, hull appendages, rigs and sails which are required to conform to F16CA standards, such boat parts only being altered to stay in line with current F16CA rules.

Part 1, Section A covers the administration of the F16CA and Section B deals with boat eligibility. Sections C to G deal with racing, and should be read in conjunction with the ISAF Equipment Rules of Sailing and the Racing Rules.

Owners and crews should be aware that compliance with rules in Section C is NOT checked as part of the certification process.

The Rules regulating the use of equipment during a race are contained in Section C of these class rules, in ERS Part I and in the Racing Rules of Sailing.

PLEASE REMEMBER:

**THESE RULES ARE CLOSED CLASS RULES
WHEREBY IF IT DOES NOT SPECIFICALLY SAY THAT YOU MAY – THEN
YOU SHALL NOT.**

COMPONENTS, AND THEIR USE, ARE DEFINED BY THEIR DESCRIPTION.

A.6 CLASS RULES AMENDMENTS

A.6.1 Amendments to these **class rules** are subject to the approval of the ISA

A.12 VALIDITY OF CERTIFICATE

A.12.1 A **certificate** becomes invalid upon:

- (a) a change to any items recorded on the **certificate** as required under A.10.1.
- (b) expiry date (if any) of the **certificate**,
- (c) withdrawal by the certification authority,
- (d) the issue of a new **certificate**,

A.12.2 Any change of ownership will be recorded on the **certificate** which will then be returned to the NCA with the appropriate fee for re-issue.

Section B – Boat Eligibility

For a **boat** to be eligible for *racing*, it shall comply with the rules in this section.

B.1 CLASS RULES AND CERTIFICATION

B.1.1 It is the responsibility of the **skipper** to ensure that the **boat** and all its **equipment** are **certified** prior to commencing a race.

B.1.2 The boat shall:

- (a) be in compliance with the **class rules**.
- (b) have a valid **certificate** for platform, **spars** and **sails**.
- (c) have valid **certification marks** as required
- (d) have a completed, signed and dated Measurement Form

B.1.3 A boat may be refused a certificate and, in this instance, the incomplete form, together with an explanation of the points in question and reason for refusal, shall be sent to the F16CA and the ISAF for a ruling in writing. (RRS 78.1 and RRS 78.3.)

B.1.4 All **certified boats** may be liable to re-measurement at the discretion of the **certification authority** or by an International Jury constituted in accordance with the RRS (Appendix N.) at an event, but only by a Measurer.

B.1.5 It is the responsibility of both designer and builder of a catamaran that is intended to be sailed within the Formula 16 Class to contact the F16CA and request that their design, or modification of an existing design, be checked and found to be in compliance with the Formula 16 rules before publicising their product as a "Formula 16" or "Formula 16 compliant".

B.2 FLOTATION CHECKS

B.2.1 The **certificate** shall carry a satisfactory flotation check confirmation.

B.3 CLASS ASSOCIATION MARKINGS

B.3.1 A valid Class Association Sticker or marking shall be affixed to each certified item as required by the NCA or the F16CA.

B.3.2 Sails shall carry a Class Association Sail Label.

PART II – REQUIREMENTS AND LIMITATIONS

The **crew** and the **boat** shall comply with the rules in Part II when *racing*. In case of conflict Section C shall prevail.

The rules in Part II are **closed class rules**. **Certification control** and **equipment inspection** shall be carried out in accordance with the ERS except where varied in this Part.

Section C – Conditions for Racing

C.1 GENERAL

C.1.1 RULES

- (a) RRS 49.1 shall not apply.
- (b) RRS 50.4 shall not apply
- (c) RRS Appendix G.1.3(d) and G.1.3(e) shall not apply
- (d) The ERS shall apply

C.2 CREW

C.2.1 LIMITATIONS

- (a) The **crew** shall consist of 1 or 2 persons, at least one of whom shall be a full member of their NCA or F16CA.
- (b) No **crew** member shall be substituted, omitted or added during an event, unless prior, written consent is obtained from the event organising committee
- (c) With 1 **crew** on board, the boat shall be sailed as a uni rig see C.10.2
- (d) With 2 **crew** on board, the boat may be sailed as a sloop see C.10.2

C.2.2 WEIGHTS

There is no minimum or maximum crew weight; save that the crew shall be capable of righting the boat unaided by external assistance in all normally encountered sailing conditions. Righting bags or poles are permitted.

C.2.3 ABILITY

The **crew** may be required by the race organisers, the NCA or the F16CA to demonstrate their ability to right the boat from a capsized position without external assistance. Such request must not affect the crews' participation in fair racing.

C.3 PERSONAL EQUIPMENT**C.3.1 MANDATORY**

- (a) The boat shall be equipped with a **personal floatation device** for each crew member to the minimum standard ISO 12402-5 (Level 50), or EN 393 50N, USCG Type III, or AUS PFD 1.

C.3.2 OPTIONAL

- (a) Trapeze harness for each **crew** member
- (b) Any other **personal equipment**

C.4 ADVERTISING**C.4.1 LIMITATIONS**

Advertising shall only be displayed in accordance the ISAF Advertising Code. (See ISAF Regulation 20)

C.5 PORTABLE EQUIPMENT**C.5.1 MANDATORY**

- (1) One distress whistle per person; securely fitted to the body or gear being worn.
- (2) At least one knife, capable of cutting the trampoline or lines found on board

C.5.2 OPTIONAL

- (1) Electronic or mechanical timing devices
- (2) One or more magnetic compasses
- (3) Towing line (if carried, a minimum length of 5m)
- (4) Water Bottle Holder(s)
- (5) Wind Indicator(s)
- (6) If carried, one anchor of not less than 2 kg in weight and with not less than 15m of line of not less than 6 mm in diameter
- (7) One paddle
- (8) Electronic navigation devices
- (9) Mobile Telephone

C.5.3 SPECIAL CASES

- (1) Boats shall comply with any special equipment requirements placed on them by a Notice of Race without penalty under any other section of these Rules.

C.6 BOAT

C.6.1 WEIGHT

The boat shall be weighed fully assembled, dry and clean. The mast will be laid flat across the platform in such a way as to achieve an equal distribution of its weight and to remain stable during weighing. The weight of the boat includes ALL items present on the boat in a ‘ready to sail’ condition excluding personal equipment and all portable equipment as listed in C.5.

- (a) The minimum weight of the uni rig **boat** in dry condition shall be 104Kg
- (b) The minimum weight of the sloop rig **boat** in dry condition shall be 107Kg

C.6.4 CORRECTOR WEIGHTS

- (a) **Corrector weights** of metal shall be permanently fastened to the front beam when the **boat** weight is less than the minimum requirement.
- (b) The total weight of such **corrector weights** shall not exceed 7 kg. See also rules A.10.1(f) and B.1.1.

C.6.5 FLOTATION

- (a) The **hull** shall be fully decked and have flotation element(s).
- (b) **Hulls** shall comply with ISO 11812 and ISO 12216.
- (c) Flotation elements shall comply with ISO 12217-3 Annex C.
- (d) **Hulls** with air tank(s) as flotation element(s) shall additionally comply with ISO 12217-3 Annex D, by test or calculation, except that the largest air tank shall not be included as a flotation element.
- (e) Adequate flotation may be demonstrated by empirical or calculation methods.

C.7 HULL

C.7.1 FITTINGS

- a) Each hull shall have at least one inspection hatch
- b) Inspection hatch covers and drainage plugs shall be kept in place at all times when *racing*.
- c) All other hull fittings are optional except where specified in these rules

C.7.2 LIMITATIONS

- a) The hulls, beams and trampoline shall not be permanently fixed to one-another. The Formula 16 Class Authority may demand that these items be disassembled, but only at a time when doing so does not directly affect the fairness of racing.

C.8 HULL APPENDAGES

C.8.1 LIMITATIONS

- (a) Only one **dagger/centreboard** and one **rudder** blade per **hull** shall be used during an event, except when a **hull appendage** has been lost or damaged beyond repair.

- (b) The **rudder** blade shall be hung from the transom of the **hull**

C.8.2 DAGGER/CENTREBOARD

(a) DIMENSIONS

There is no minimum or maximum dimension for a **dagger/centreboard** or a requirement for one to be fitted to a **hull** at all.

(b) USE

If fitted, **daggerboards/centerboards** shall conform to the following:

- i. The board shall be inherently straight in length;
- ii. Asymmetrical chord cross-section is optional
- iii. When in the fully down position, fore/aft movement of **daggerboards** will not be allowed.
- iv. End fences/horizontal appendages below the waterline will not be allowed. The board shall be capable of removal, without tools, via the upper opening of the case.
- v. **Dagger/centerboards** shall not be canted at greater than 6° from the vertical in the 'bow on' view when the boat is level on the waterline.

C.8.3 RUDDER

(a) DIMENSIONS

- i) There is no minimum or maximum dimension for rudders save that there shall be one **rudder** per hull.
- ii) Trim tabs, fences and appendages are permitted.

(b) LIMITATIONS

The **rudder** retention devices shall retain the **rudders**, in the event of capsize.

(c) USE

Any device for adjusting the angle of any appendages or trim tabs to the rudder blade shall remain locked whilst *racing*.

C.9 RIG

C.9.1 FITTINGS

- (a) The **mast** pivot shall be fixed on the centreline of the front beam.
- (b) **Sail** and **mast** adjustment fittings may be fitted.
- (c) **Forestay**, diamond stays and shroud tension/rake adjustment devices or fittings are permitted.

C.9.2 LIMITATIONS

- (a) Only one set of **spars** and **standing rigging** shall be used during an event, except when an item has been lost or damaged, and the Race Committee has approved the substitution.
- (b) Replacement of damaged **spars** may only be made with the approval of the Race Committee.

- (c) Adjustment of mast rake, the tension of the standing rigging, the angle or length of the spreaders and the position of the **bowsprit** while *racing* is not permitted.
- (d) Adjustment of all other items not listed in C.9.2(c) above, including diamond stays, is permitted while *racing*.

C.9.3 MAST

- (a) The **mast** shall be stepped on the centreline of the boat.

C.9.4 BOOM

- (a) The **boom** may have fittings attached.

C.9.5 BOWSPRIT

- (a) The **bowsprit** shall be attached to the front beam.
- (b) The **bowsprit** shall be fixed on the fore and aft centreline of the boat and shall not be adjusted while *racing*.
- (d) The **bowsprit** may have fittings attached.
- (e) The **bowsprit** may have wind indicator(s) attached.

C.9.6 RUNNING RIGGING

- (a) All running rigging may be led at the option of the **crew**.

C.10 SAILS

C.10.1 MODIFICATIONS, MAINTENANCE AND REPAIR

- (a) Routine maintenance such as repairs to seams and patching not involving panel replacement is permitted without re-measurement and re-certification.
- (b) Battens may be placed or replaced in the **batten pockets**

C.10.2 LIMITATIONS

- (a) Uni Rig – 1 crew
 - (i) Not more than 1 mainsail, and 1 spinnaker shall be carried aboard.
 - (ii) Not more than 1 mainsail, and 1 spinnaker shall be used during an event, except when a **sail** has been lost or damaged beyond repair.
- (b) Sloop Rig – 2 Crew
 - (i) Not more than 1 mainsail, 1 jib, and 1 spinnaker shall be carried aboard.
 - (ii) The jib may be omitted if the **crew** so elect. If the jib is omitted the boat must still meet the minimum weight requirement for a sloop rig boat.
 - (iii) Not more than 1 mainsail, 1 jib and 1 spinnaker shall be used during an event, except when a **sail** has been lost or damaged beyond repair.

D.2.2 CERTIFICATION

Only the controls, measurements and calculations made by a measurer recognized by the F16CA, a MNA or ISAF are considered valid.

D.2.3 Modifications, Maintenance and repair

- (a) Routine maintenance such as painting and polishing is permitted without re-measurement and re-**certification**.

D.2.4 IDENTIFICATION

- (a) Hulls shall have a unique serial number
- (b) From, all new **hulls** shall carry an ISAF Plaque permanently placed on one transom or on the inside of the hulls just below the rear beam.

D.2.6 BUILDERS

- (a) A licence is not required to build an F16 catamaran

D.3 HULL SHELL**D.3.1 MATERIALS**

- (a) The **hull** shell shall be built from any material commercially available
- (b) Each **hull** shall carry flotation in line with C.6.5.

D.4 DECK**D.4.1 MATERIALS**

- (a) The **deck** shall be built from any material commercially available

D.5 BEAMS**D.5.1 MANDATORY**

- (a) Front beam (also referred to as the main beam)
- (b) Mast step
- (c) Rear beam

D.5.2 CONSTRUCTION

- (a) The beams shall be made of any material commercially available
- (b) The **mast** pivot on the main/front beam shall be fixed on the centreline of the boat.
- (c) The main/front beam may have a strut and tie of optional material.
- (d) The rear beam may incorporate a mainsail traveller track.
- (e) The main/front beam may incorporate a jib traveller track and/or a self tacking system.
- (f) Local reinforcement is permitted inside the main/front beam for the mast step.

- (g) Local reinforcements are permitted inside the main/front beam and the rear beam for supporting fixing bolts.
- (h) The **mast** step shall be in a fixed position
- (i) The beams may accommodate adjustment fittings

D.6 TRAMPOLINE

D.6.1 MATERIALS

- (a) optional, except that netting is prohibited

D.6.2 CONSTRUCTION

- (a) A single trampoline, which may be in separate sections, shall cover the area between the front beam and the rear beam.
- (b) Lacing and lacing eyes are permitted.
- (c) A spinnaker bag is permitted.
- (d) Storage bags and pouches are permitted.
- (e) Stainless steel wire or synthetic lines for tensioning the trampoline are permitted.
- (f) The trampoline may have fittings attached.

D.7 ASSEMBLED HULL

D.9.1 FITTINGS

(a) MANDATORY

- (1) Forestay bridle fitting
- (2) Shroud plates

(b) OPTIONAL

- (1) Trampoline fitting attachments.
- (2) **Bowsprit** fitting attachments
- (2) Foot loops, toe straps, trapeze gear, crew restraining line.
- (3) Centreboard/daggerboard retention/placement fittings.
- (4) **Hulls** may have fittings attached.
- (5) Additional inspection hatches.

D.9.2 DIMENSIONS

- (a) The maximum length of each hull, measured excluding any rudder fitting, shall be **5.00 metre**.
- (b) The maximum beam of the platform (hulls and beams assembled) shall be **2.50 metre**.
- (c) Fixed or retracting wings may be carried as long as the equivalent maximum overall beam, when measured from the opposite **hull** gunwale, over the platform AND one fully extended (if applicable) wing is **2.50 metre** or less.

D.9.3 CONSTRUCTION

- (a) The **hulls** shall be joined rigidly by a front beam and a rear beam.

- (b) Sealing strips of any suitable material for centreboard/daggerboard slots (if fitted) are permitted.
- (c) Traveller and/or trampoline tracks may be fitted to the **hulls**.
- (d) Non slip surfaces, built in or applied to the **hulls**, are allowed.

Section E – Hull Appendages

E.1 PARTS

E.1.1 MANDATORY

- (a) **Rudders**
- (b) **Tillers**
- (c) **Tiller** connecting bar

E.1.2 OPTIONAL

- (a) **Centreboard**
- (b) **Daggerboard**
- (c) **Tiller** extension

E.2 GENERAL

E.2.1 RULES

- (a) **Hull appendages** shall comply with the **class rules** in force at the time of **certification**.

E.2.2 MODIFICATIONS, MAINTENANCE AND REPAIR

- (a) **Hull appendages** shall not be altered in any way except as permitted by these class rules.
- (b) Routine maintenance such as cleaning and sanding is permitted without re-measurement and **re-certification**. See RRS 53.

E.2.3 CERTIFICATION

- (a) A measurer recognized by the F16CA, a MNA or ISAF shall **certify hull appendages** and shall number the **certification mark**.

E.2.4 MANUFACTURERS

- (a) A licence is not required to manufacture **hull appendages**.

E.3 DAGGERBOARD/CENTREBOARD

E.3.1 RULES

- (a) The **centreboard/daggerboard** shall comply with the **class rules** in force at the time of the **certification**. A measurer recognized by the F16CA, a MNA or ISAF shall **certify centreboards/daggerboards** and shall number the **certification mark**. There shall be a maximum of one **centreboard/daggerboard** per hull.

E.3.2 MATERIALS

- (a) The **centreboards/daggerboards** may be made using carbon fibre, glass fibre, wood, foam plastics, resins, paints, glues and metal fastenings.

E.3.3 CONSTRUCTION

- (a) The **daggerboards/centreboards** shall have no moving parts.
- (b) **Ballast** is not permitted.
- (c) Lightening holes or cut-outs are permitted

E.3.4 FITTINGS

- (a) Pivot bushings and height restraining systems may be fitted.

E.4 RUDDER BLADE, RUDDER STOCK AND TILLER

E.4.1 RULES

- (a) The **rudder** blade shall comply with the **rules** in force at the time of **certification**.

E.4.2 CERTIFICATION

- (a) A measurer recognized by the F16CA, a MNA or ISAF shall **certify rudder** blades and shall number the **certification mark**.

E.4.3 MATERIALS

- (a) **Rudder** blade may be made using carbon fibre, glass fibre, wood, foam plastics, resins, paints, glues and metal fastenings.
- (b) The **rudder** stock shall be made from any commercially available material.
- (c) The tiller and extension shall be made from any commercially available material.

E.4.4 CONSTRUCTION

- (a) The cross section of each **rudder** shall be symmetrical about its fore and aft centre line.

E.4.5 FITTINGS

(a) MANDATORY

- (1) 2 rudder fittings
- (2) Rudder stock / Rudder retaining mechanism or clip

(b) OPTIONAL

- (1) 2 gudgeons.
- (2) 2 pins or pintles.
- (3) Pivoting and/or lowering systems.

Section F – Rig

F.1 PARTS

F.1.1 MANDATORY

- (a) **Mast**
- (b) Standing **rigging**
- (c) Running **rigging**
- (d) **Bowsprit**

F.1.2 OPTIONAL

- (a) **Boom**
- (b) **Spinnaker** retrieval system

F.2 GENERAL

F.2.1 RULES

- (a) The **spars** and their fittings shall comply with the **rules** in force at the time of **certification** of the **spar**.
- (c) The **boom** (if fitted), **bowsprit**, all standing and all running **rigging** shall comply with the **class rules**.

F.2.2 MODIFICATIONS, MAINTENANCE AND REPAIR

- (a) **Spars** shall not be altered in any way except as permitted by these **Class Rules**.
- (b) Routine maintenance such as cleaning and minor repairs is permitted without re-measurement and **re-certification**.

F.2.3 CERTIFICATION

- (a) A measurer recognized by the F16CA, a MNA or ISAF shall **certify spars** and shall number the **certification mark**.
- (b) **Certification** of standing and running **rigging, bowsprit** and **boom** is not required.
- (c) Each **mast** shall have a **certification mark** on the starboard side.

F.2.4 MANUFACTURER

- (a) A licence is not required to manufacture **spars**.

F.2.5 DEFINITIONS

(a) MAST DATUM POINT

The **mast datum point** is located at the front edge of the mast **spar**, on the longitudinal axis, on the lower end of the profile. See Appendix I.

F.3 MAST

F.3.1 MATERIALS

- (a) The **mast** shall be made of aluminium, wood or carbon fibre and epoxy resin.

F.3.2 CONSTRUCTION

- (a) The **mast** may have no more than one fixed sail groove, which may be integral with the **mast spar**
- (b) The **mast** shall have one masthead fitting, which may include the mainsail locking device.
- (c) The **mast** shall have a heel fitting attached.
- (d) The **mast** shall be designed and constructed so that the **mast tip** is sealed to prevent ingress of water

F.3.3 DIMENSIONS

- (a) The **mast** may be tapered.
- (b) The position of the **lower limit mark** shall be determined following sail measurement
- (c) The **mast** shall be measured while straight.
Mast spar curvature maximum 10mm – see ERS F2.3(k) and ERS H4.3
- (d) The distance between limit marks (BD) – see Appendix I – shall be calculated using the formula;

$$BD = A + 2 \times ((15 - RA) / P) \quad \text{see Appendix J(X.1) for terms}$$

	minimum	maximum
Mast spar circumference		500 mm
Distance between top of the front beam and the mast datum point (mast foot height)		75 mm
Mast datum point to upper limit mark		8500mm
Mast tip to upper limit mark		75mm
Upper limit mark to lower limit mark		By calculation
Mast limit mark width	20mm	
Spinnaker hoist height		7500 mm
Mast tip weight	6.00Kg	

F.3.4 FITTINGS

(a) MANDATORY

- (1) One masthead fitting which may include the mainsail locking device.

- (2) Heel fitting.
- (3) Hounds fittings.

(b) OPTIONAL

- (1) Pair of adjustable rake spreader bars and fittings
- (2) Diamond stay attachment and adjustment fittings
- (3) Spinnaker halyard guide
- (4) Spinnaker halyard block and attachments
- (5) Gooseneck fittings
- (6) **Mast** rotation control fittings
- (7) **Mast** may have reinforcement at fittings points
- (8) Cunningham downhaul fittings
- (9) The **mast** may have other fittings not here listed

F.4 BOOM

F.4.1 MATERIALS

- (a) The **boom**, if fitted, shall be made of aluminium, wood or carbon fibre / epoxy resin.

F.4.2 CONSTRUCTION

- (a) The **boom** may include a fixed sail groove or track which may or may not be integral with the boom.

F.4.3 FITTINGS

- (a) Adjustment fittings are optional.

F.5 BOWSPRIT

F.5.1 RULES

- (a) The **bowsprit** shall be on the longitudinal centreline of the boat.

F.5.2 MATERIALS

- (a) The **bowsprit** shall be made of any commercially available material

F.5.3 CONSTRUCTION

- (a) The **bowsprit** shall have an end cap and be smooth rounded and blunt.
- (b) The **bowsprit** may have a “snuffer” attachment.

F.5.4 FITTINGS

- (a) MANDATORY
 - (1) Attachment points to hull shells.
- (b) OPTIONAL
 - (1) Adjustment fittings.

F.5.5 DIMENSIONS

- (a) The maximum length of the **bowsprit** shall be 3.50m measured from the leading edge of the main beam to the end cap.

F.6 STANDING RIGGING**F.6.1 MATERIALS**

- (a) The **standing rigging** consisting of shrouds, mast diamond stays, **forestay** and bridles shall be free in material choice
- (c) The **forestay** shall be on the centreline of the boat.
- (d) Trapeze lines may have adjustable height fittings.

F.7 RUNNING RIGGING**F.7.1 MATERIALS**

- (a) Materials are optional.

F.7.2 CONSTRUCTION**(a) MANDATORY (SLOOP OR UNI RIG)**

- (1) Mainsail sheet.
- (3) Spinnaker halyard.
- (4) Spinnaker sheets.

(b) MANDATORY (SLOOP RIG)

- (1) Jib Halyard
- (2) Jib Sheet

(c) OPTIONAL

- (1) Mainsail Cunningham line.
- (2) Mainsail halyard
- (3) Mainsail outhaul.
- (4) Jib Cunningham line.
- (5) Spinnaker tack outhaul line.
- (6) Single spinnaker uphaul / downhaul and retrieval line.
- (7) Mast rotation control lines.
- (8) Any other adjustment fitting at the option of the crew

Section G – Sails

G.1 PARTS

G.1.1 SAIL TYPES

- (a) Mainsail
- (b) Jib
- (c) Spinnaker

G.2 GENERAL

G.2.1 RULES

- (a) **Sails** shall comply with the **rules** in force at the time of **certification**.

G.2.2 CERTIFICATION

- (a) A measurer recognized by the F16CA, a MNA or ISAF shall **certify** all sails.
- (b) The ISAF or an MNA may appoint one or more **In-House Official Measurers** to measure and **certify sails** produced by that manufacturer.

G.2.3 SAILMAKER

- (a) A licence is not required to manufacture sails.
- (b) From 1st July 2010 and beyond, the material of the **body of the sail** shall be indelibly marked, by a plaque or label, near the **tack point** by the sailmaker together with the year date, the material from which the **sail** was made and a serial number.

G.3 MAINSAIL

G.3.1 IDENTIFICATION

- (a) The Class insignia shall conform to the dimensions and requirements as detailed and be placed in accordance with the diagram contained in Appendix H(X.1).
- (b) Only a design specific insignia or the official F16 insignia may be placed in the top 1/3 of the mainsail.

G.3.2 MATERIALS

- (a) The mainsail shall be constructed from a commercially available sailcloth material.

G.3.4 CONSTRUCTION

- (a) The construction shall be that of a **soft sail**.
- (b) The **body of the sail** shall consist of the same woven and/or **laminated ply** throughout.
- (c) The **sail** may have **batten pockets** which may extend from **leech** to **luff**.

- (d) The **sail** may be constructed so that it can be reefed by means of reefing point(s) adjacent to the **luff**, point(s) adjacent to the **leech** and corresponding point(s) in the **body of the sail**.
- (e) The following are permitted: stitching, glues, tapes, bolt ropes, corner eyes, headboard with fixings, Cunningham eye or pulley, battens, **batten pocket patches**, batten pocket elastic, batten pocket end caps, mast and boom slides, leech line with cleat, one or more **window(s)**, tell tales, sail shape indicator stripes and items as permitted or prescribed by other applicable rules.
- (f) The **foot** may be convex.

G.3.5 DIMENSIONS

The sail shall be measured in accordance with the F16 Measurement form (see Appendix J(X.1)) and the ERS Section G

	minimum	maximum
Sail area (including the side area of the mast spar)	-	15 m ²
Mainsail luff length	-	8100mm

G.4 JIB

G.4.1 MATERIALS

- (a) The mainsail shall be constructed from a commercially available sailcloth material.

G.4.2 CONSTRUCTION

- (a) The construction shall be that of a **soft sail**.
- (b) The **body of the sail** shall consist of the same woven and/or **laminated ply** throughout.
- (c) The **sail** may have **batten pockets** which may extend from **leech** to **luff**.
- (d) The following are permitted: stitching, glues, tapes, corner eyes, headboard with fixings, Cunningham eye or pulley, zips, Velcro and sleeve **luff**, battens, **batten pocket patches**, batten pocket elastic, batten pocket end caps, leech line with cleat, tell tales, one **window** and items as permitted or prescribed by other applicable *rules*.

G.4.3 DIMENSIONS

The sail shall be measured in accordance with the F16 Measurement form (see Appendix J(X.2)) and the ERS Section G

	minimum	maximum
Sail area	-	3.70 m ²
Luff length (A)	-	6000mm
Leech length (C)	-	6000mm

G.5 SPINNAKER**G.5.1 MATERIALS**

- (a) The **ply** fibres shall consist only of nylon or polyester materials

G.5.2 CONSTRUCTION

- (a) The construction shall be: **soft sail, single ply sail**.
- (b) **Primary and secondary reinforcement** is permitted at the **sail corners** and the recovery points.
- (d) The following are permitted: stitching, glues, tapes, corner eyes, recovery line eyes, tell tales, leech lines and items as permitted or prescribed by other applicable *rules*.
- (e) The area and the dimensions of the spinnaker (**luff length, leech length, half width, foot length**) shall be written in an indelible manner near the starboard tack (the sailmakers label or foot tape may be used).

G.5.3 DIMENSIONS

The sail shall be measured in accordance with the F16 Measurement form (see Appendix J(X.3)) and the ERS Section G

	minimum	maximum
Sail area		17.5 m ²
Ratio of half width (SMG)/ foot length (SF)	75%	

PART III – APPENDICES

Section H

APPENDIX H(X.1)

CLASS INSIGNIA AND POSITION ON SAIL

A **certified** F16 Catamaran shall carry an official F16 logo on the **mainsail** such that it conforms to the following:

1. The logo maximum dimensions shall be 200mm high and 300mm wide
2. The top of the port side logo shall be a minimum of 900mm and a maximum of 1500mm from the lower outside edge of the **mainsail clew**.
3. The foremost point of the logo shall be a minimum of 500mm and a maximum of 800mm from a point where a line extended across the top of the logo crosses the **mainsail leach**
4. The starboard logo shall be placed immediately above the port logo but on the starboard side of the **mainsail**.
5. The official F16 logo may be obtained from the F16CA

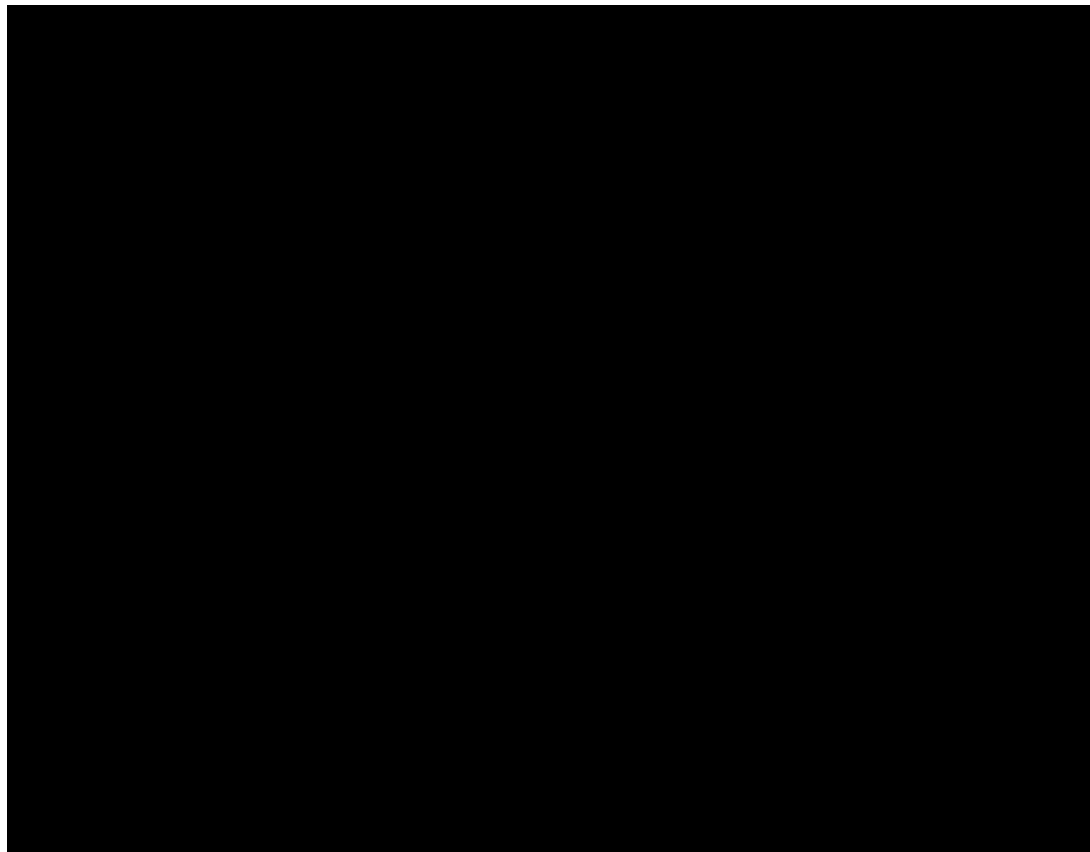

Section I

APPENDIX I(X.1)

MAST DATUM POINT AND MEASUREMENTS

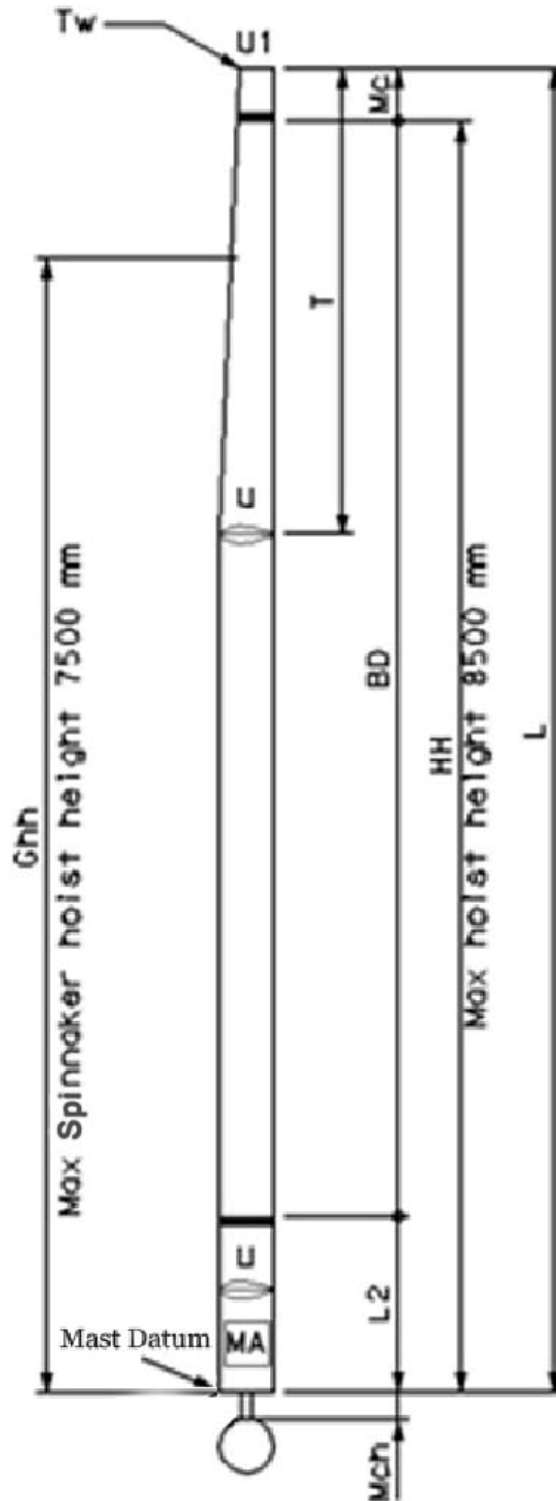

Section J

APPENDIX J(X.1)

MAINSAIL MEASUREMENTS

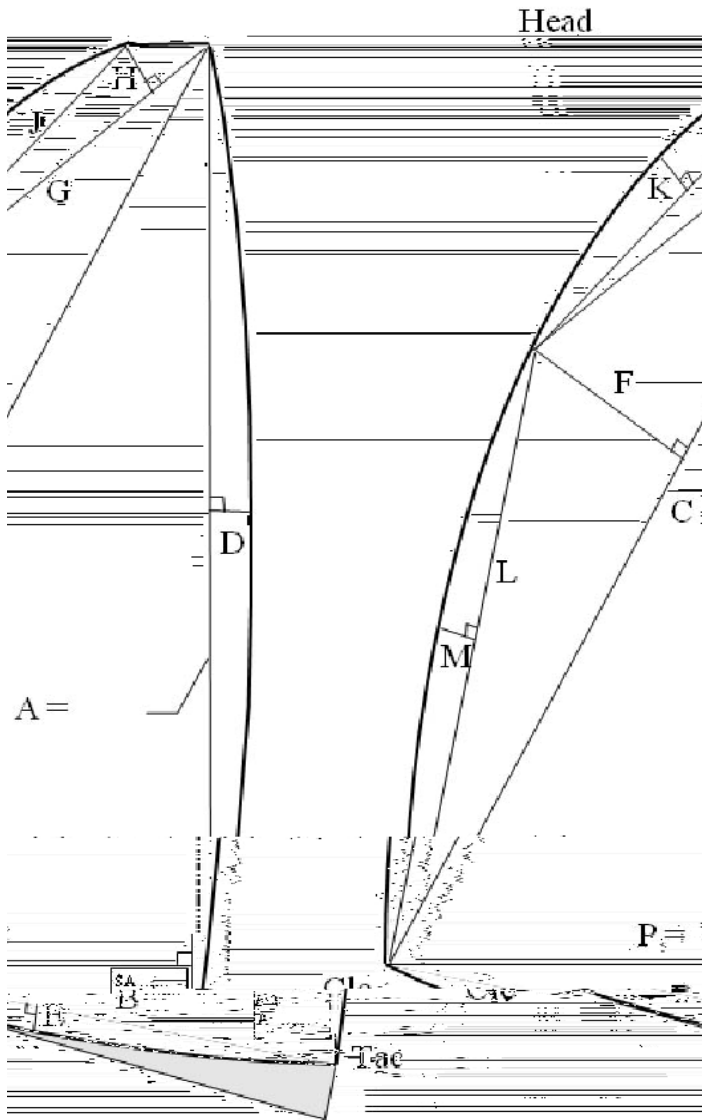

Sail	Measure	Calc
Luff = A		[m]
D		[m]
C		[m]
F		[m]
G		[m]
H		[m]
J		[m]
K		[m]
L		[m]
M		[m]
Base = P		[m]
B		[m]
E		[m]
Main Triangle		$1/2 (A \times P)$
Luff Round		$2/3 (A \times D)$
Foot Round		$2/3 (B \times E)$
Roach Area 1		$1/2 (C \times F)$
Roach Area 2		$1/2 (H \times G)$
Roach Area 3		$2/3 (J \times K)$
Roach Area 4		$2/3 (L \times M)$
Sail Area = SA		[m²]
Mast area= MA		[m²]
Total Sail Area = RA		[m²]

Mast area = mast length * maximum circumference of the mast * 0.5

APPENDIX J(X.2)

JIB MEASUREMENTS

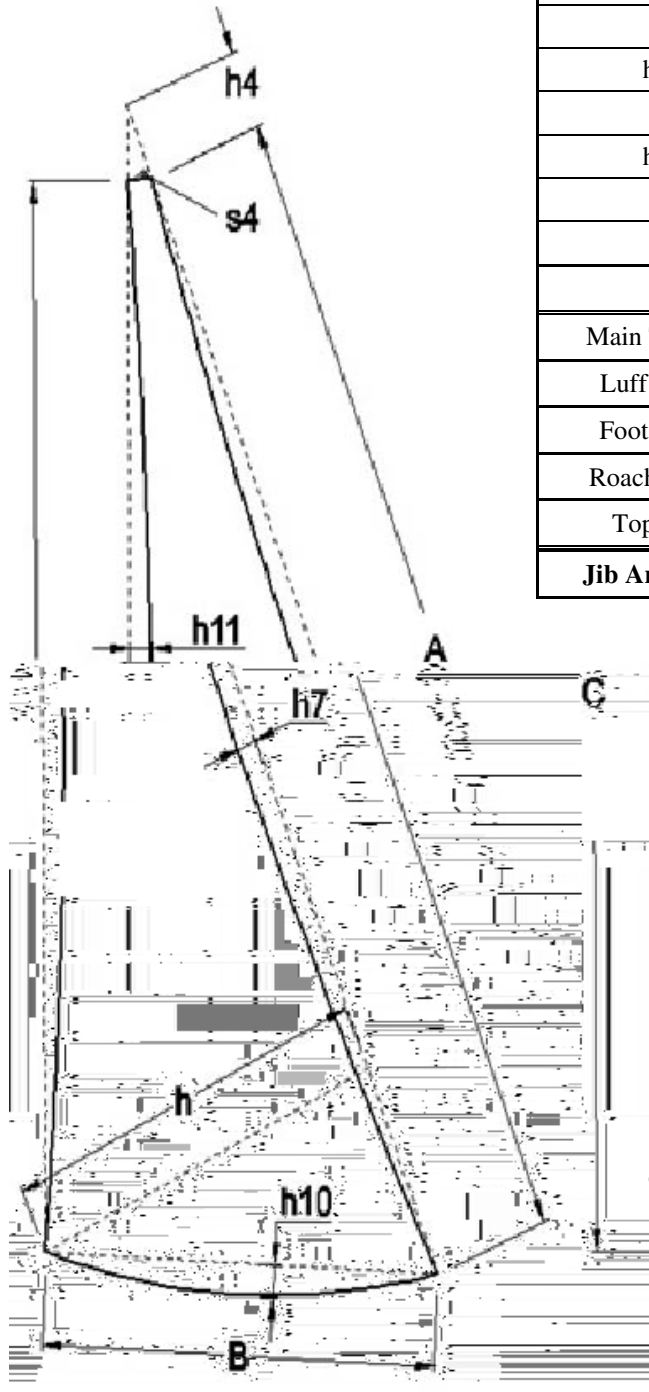

Jib	Measure	Calc
Luff = A		[m]
h7		[m]
C		[m]
h11		[m]
B		[m]
h10		[m]
h		[m]
s4		[m]
h4		[m]
Main Triangle		$1/2 ((A+h4) \times h)$
Luff Round		$2/3 (A \times h7)$
Foot Round		$2/3 (B \times h10)$
Roach Area 1		$2/3 (C \times h11)$
Top Area		$1/2 (s4 \times h4)$
Jib Area = JA		[m²]

APPENDIX J(X.3)

SPINNAKER MEASUREMENTS

Spinnaker	Measure	Calc
SL1		[m]
SL2		[m]
SMG		[m]
SF		[m]
Ratio		% SMG /SF
Spinnaker Area = SP		[m²]

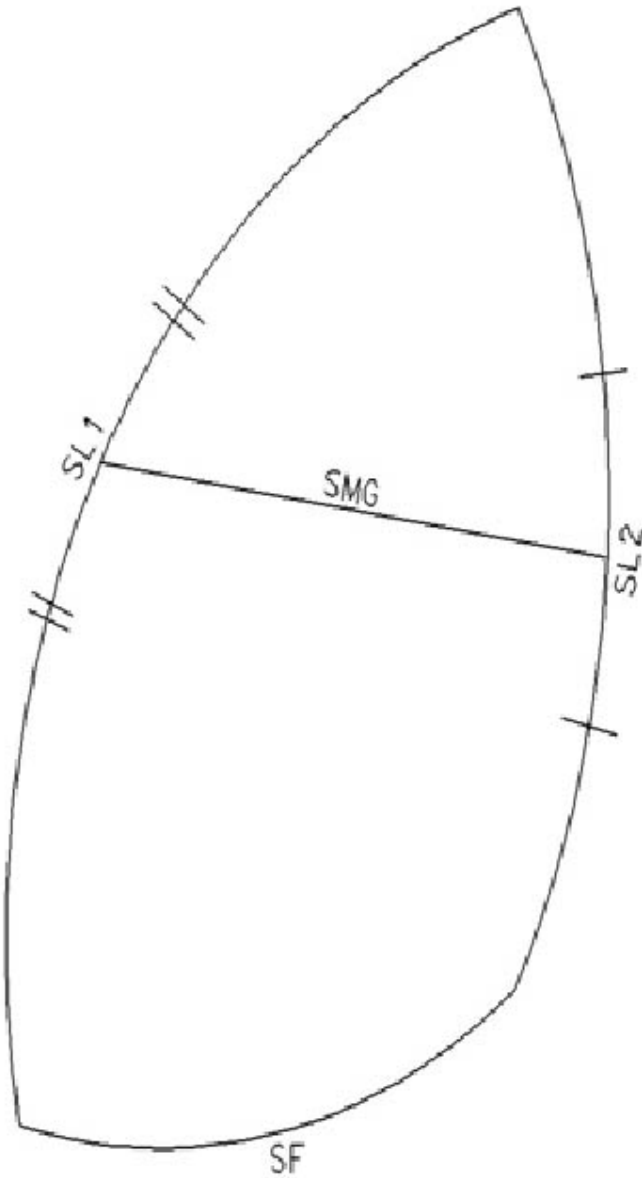

Max. Spinnaker area (SP) = SF * (SL1+SL2) / 4 + (SMG-SF/2) * (SL1+SL2) / 3 = 17.5 m²

Effective Date:

Published Date:

Previous issues: *none*

© ISAF 2009